



All Hipac CLIK™ products are designed to reduce potential ligature risks within mental health establishments and places where there is a risk of self-harm.

Hence these products need to be installed by a tradesperson, suitable equipped to ensure a professional and risk free installation. Unless specifically stated otherwise, the screws provided with all Hipac CLIK™ products are stainless steel for corrosion resistance and are 6 lobe-pin anti-tamper screws. Under no circumstances should the screws be substituted with conventional fixings.

Only use the anti-tamper screws provided. Do not use impact drivers.

Tools required

Drill

Hex Socket Screwdriver

T20 Pin-Torx Bit

T25 Pin-Torx Bit

T10 Pin-Torx Bit

Drill Bits 5.5mm

Pencil

Straight Edge

Combination Square

Tape Measure

Contents

Page 2	Wall Mounted Fittings
Page 3-5	Fitting the Wall Mounted Bracket
Page 6-7	Fitting the Top Fix Bracket
Page 7	Top Fix Fittings
Page 8	Shower Track Assembly



Wall Bracket Mounted Products



Oval Towel Ring

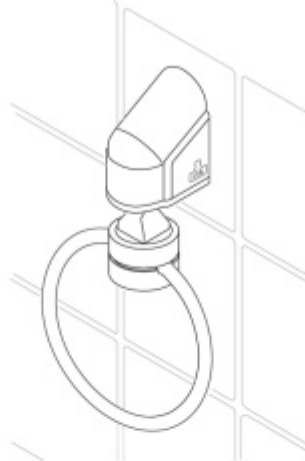

Round Towel Ring

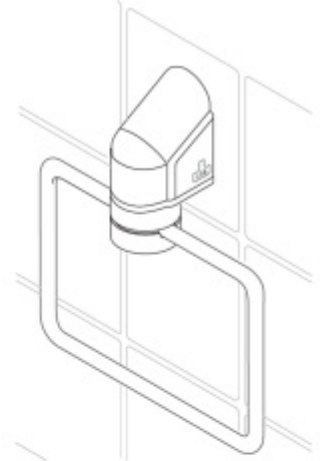

Square Towel Ring



Oval Toilet Roll Holder



Square Toilet Roll Holder

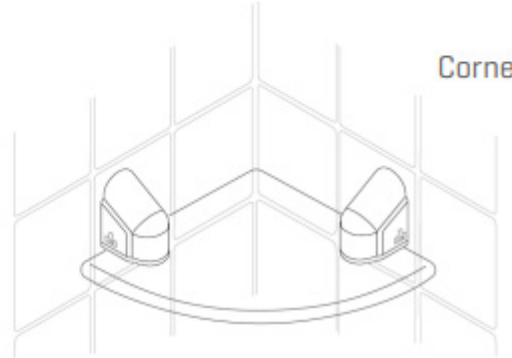

Corner Shelf

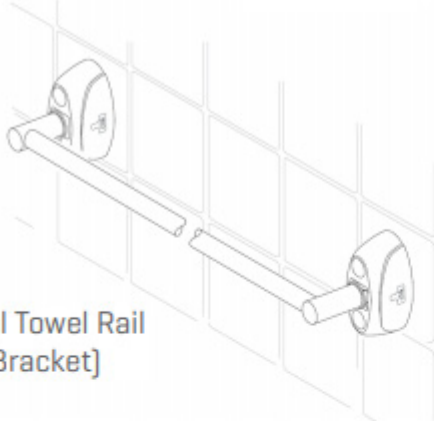

Conventional Towel Rail
[Top Fix Bracket]

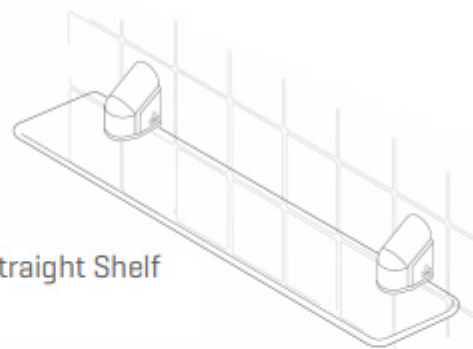

Straight Shelf



Soap Dish

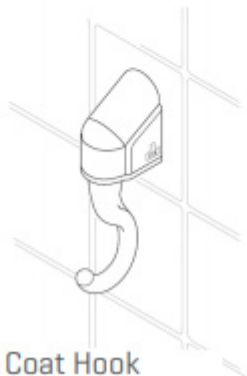

Coat Hook

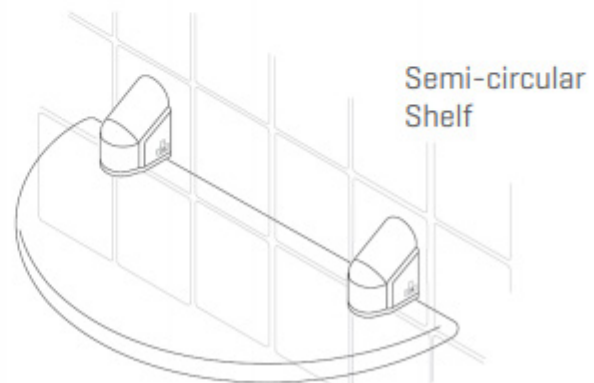

Semi-circular Shelf



Component Parts

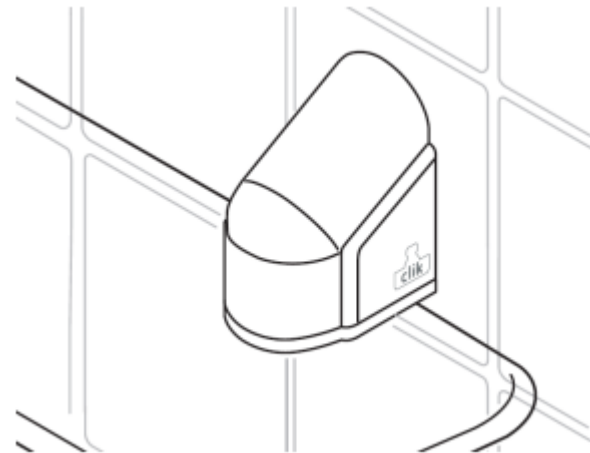
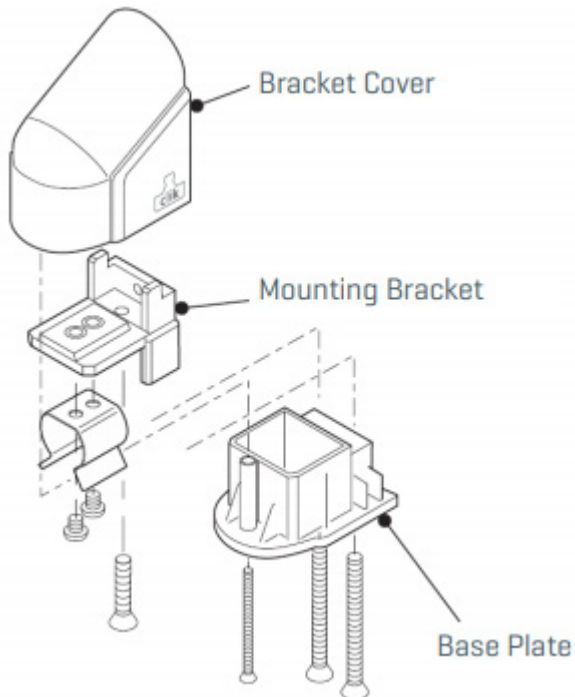

[Determine the locations for the wall brackets with the product to be installed]

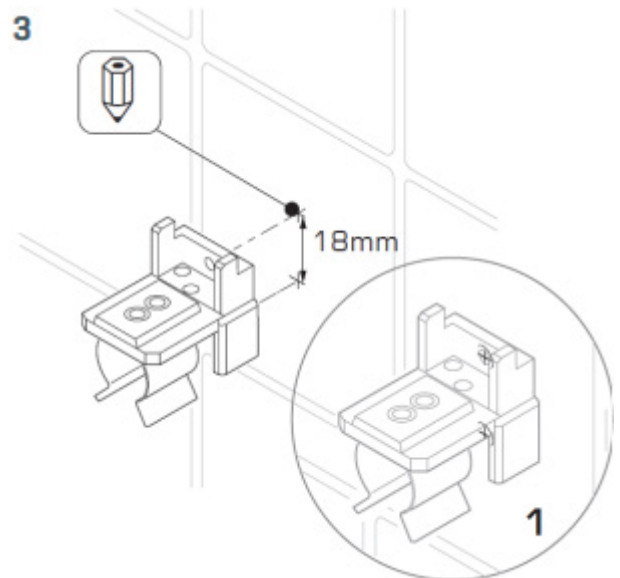
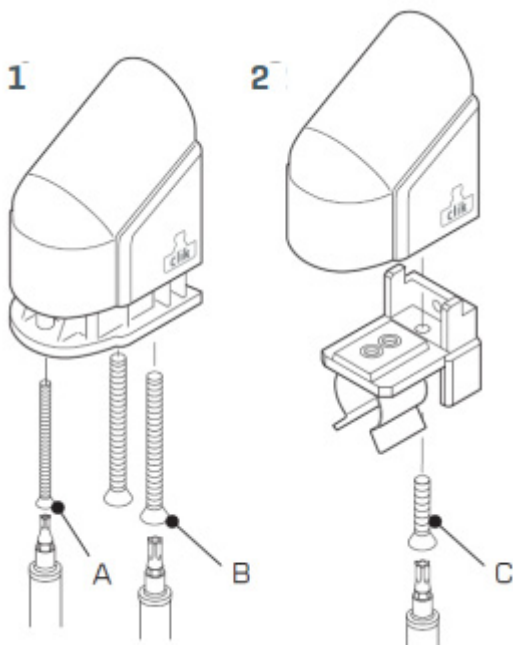

1. To disassemble the wall bracket unscrew the T10 Torx Screw A at the front of the bracket. Using a T20 Pin Torx driver remove the remaining two machine screws B to separate the base-plate from the mounting bracket.
2. Remove the machine screw C and slide the bracket cover off.
3. Using the mounting bracket as a guide, mark the position of the uppermost mounting screw. Measure and mark a line 18mm vertically down from the centre of this point for the lower fixing point. Before drilling, use the bracket to conform alignment inset.



4. Where more than one bracket is used installation is it good practice to click the item into the spring clips and offer the assembly into position before marking. Mark the position of the uppermost mounting screw on each bracket. Ensure correct alignment prior to drilling.

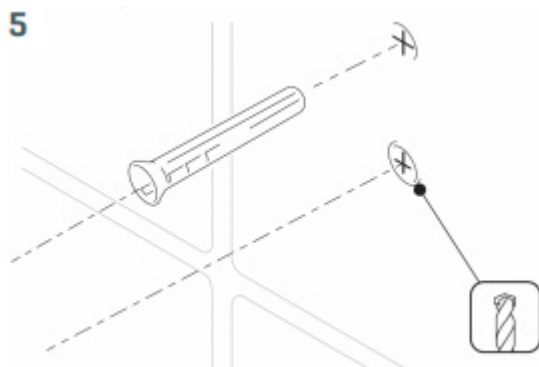
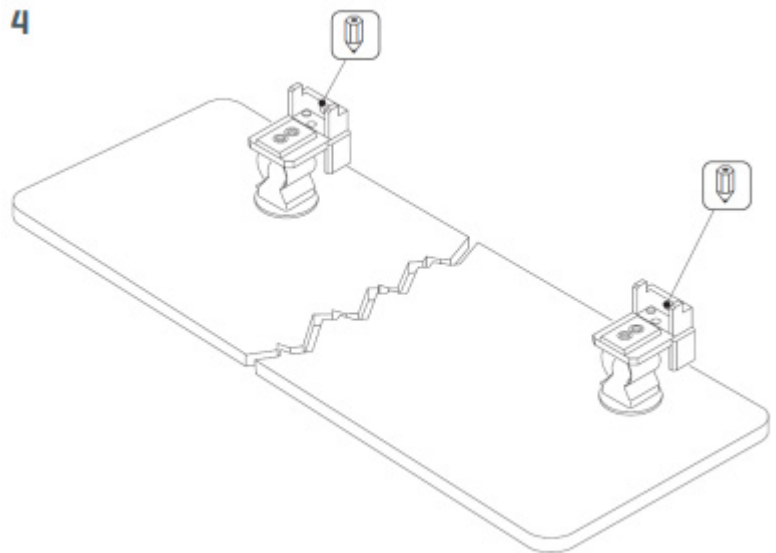

5. When mounting to a timber laminated surface, use a 3mm HSS drill bit to create pilot holes for the screws. When mounting onto a wall (or tiled surface) use a 5.5mm masonry bit for the wall-plugs provided.

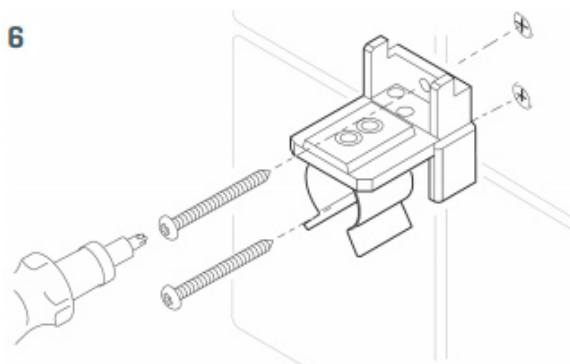

6. Fit the bracket using the fixings supplied. Ensure mounting bracket is securely fastened to the wall.
7. Refit the cover and base-plate using the screws provided.

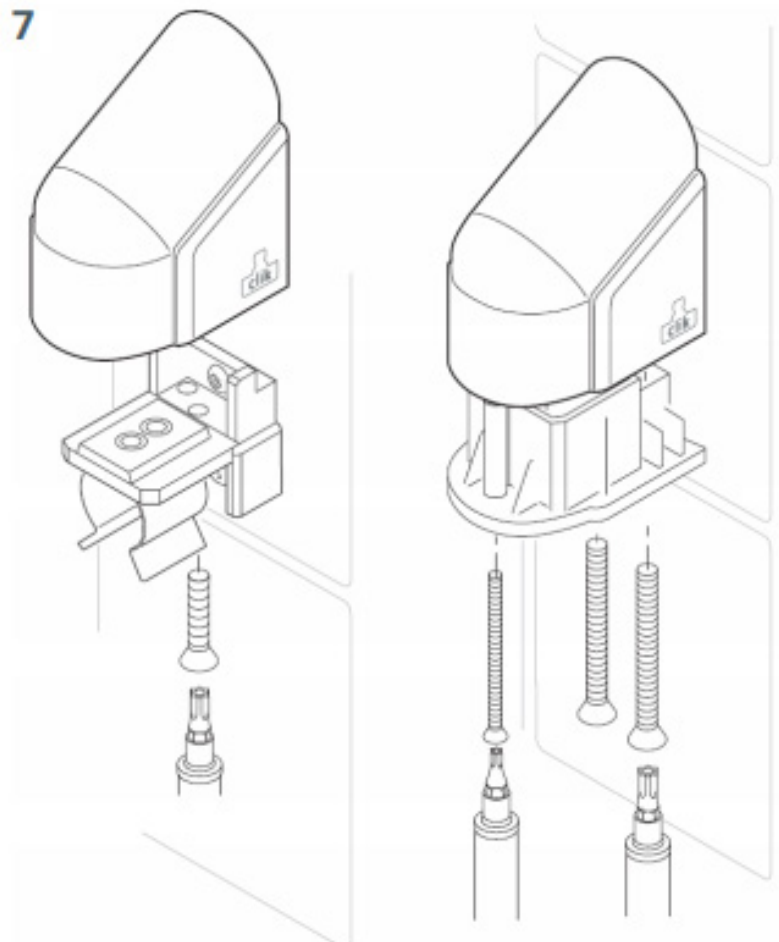

IMPORTANT NOTE: It is imperative that there are no gaps between the wall bracket cover and mounting surface.

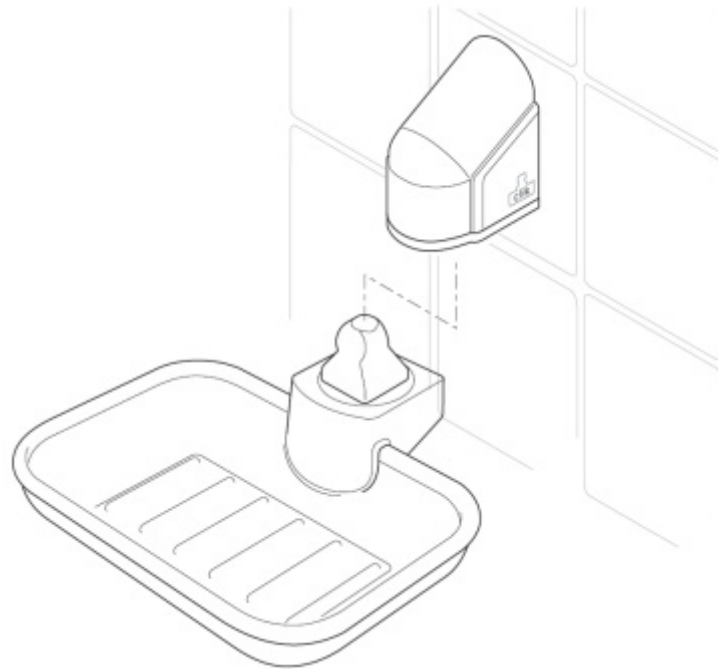

CLIK™ the product into the bracket

Wall Fix Curtain Track

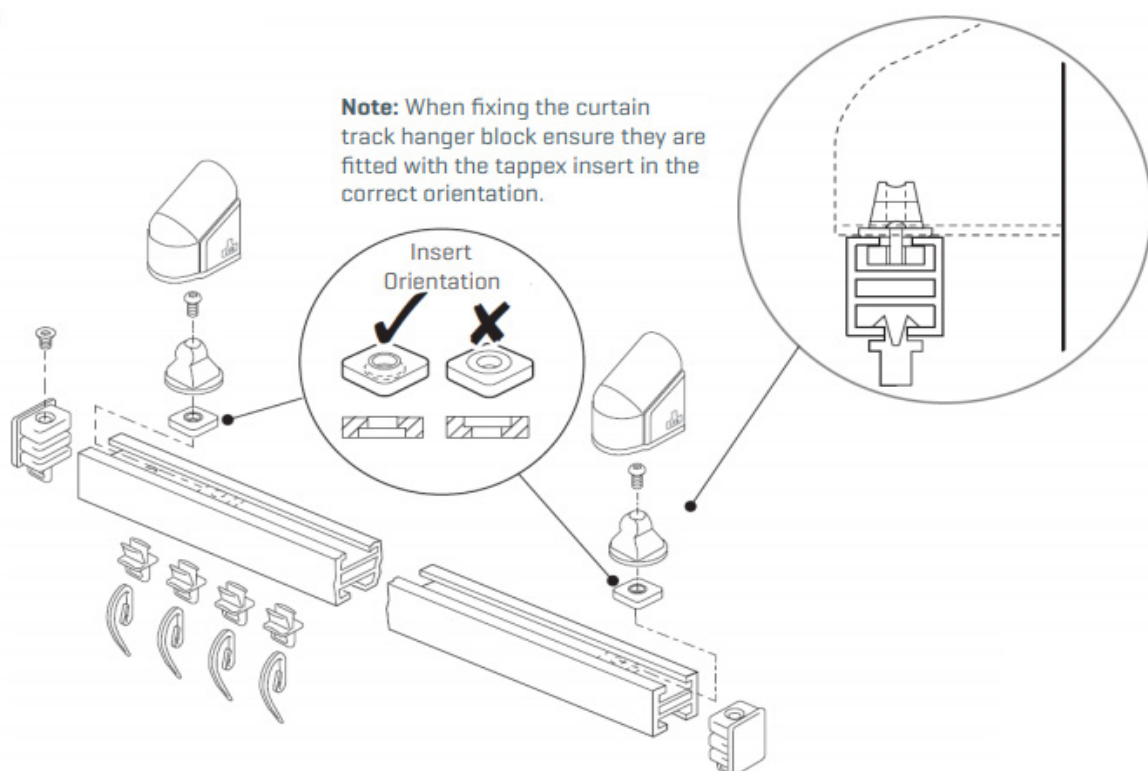



Top Fix Bracket Component Parts

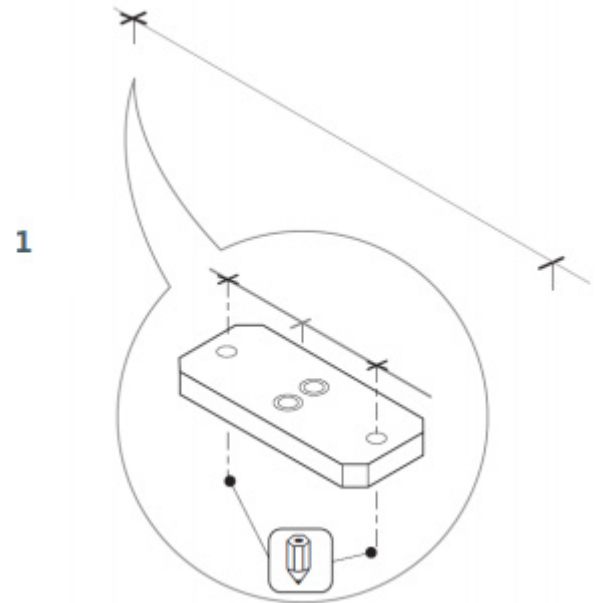
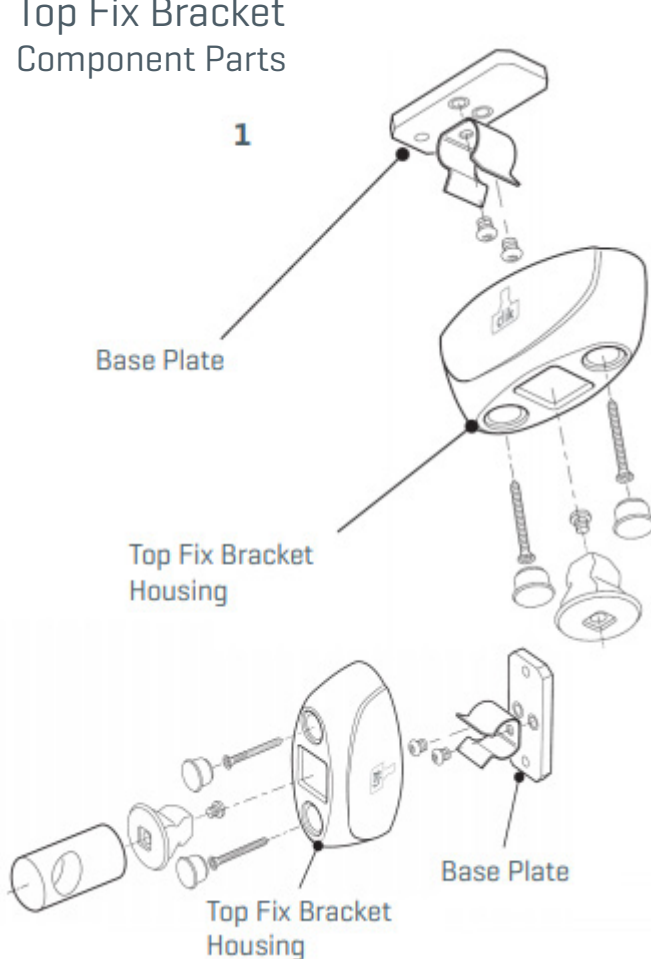

3. Having first established a suitable datum line for the product to be installed, use the base plate as a template to mark the position of the fixings for the first bracket.

1. Separate the base-plate from the bracket housing. [Determine the location for the top fix bracket with the product to be installed].
2. Where more than one bracket is used in the installation it is good practice to click them into the spring clips and offer the assembly up to mark their position. Ensure correct alignment prior to drilling.

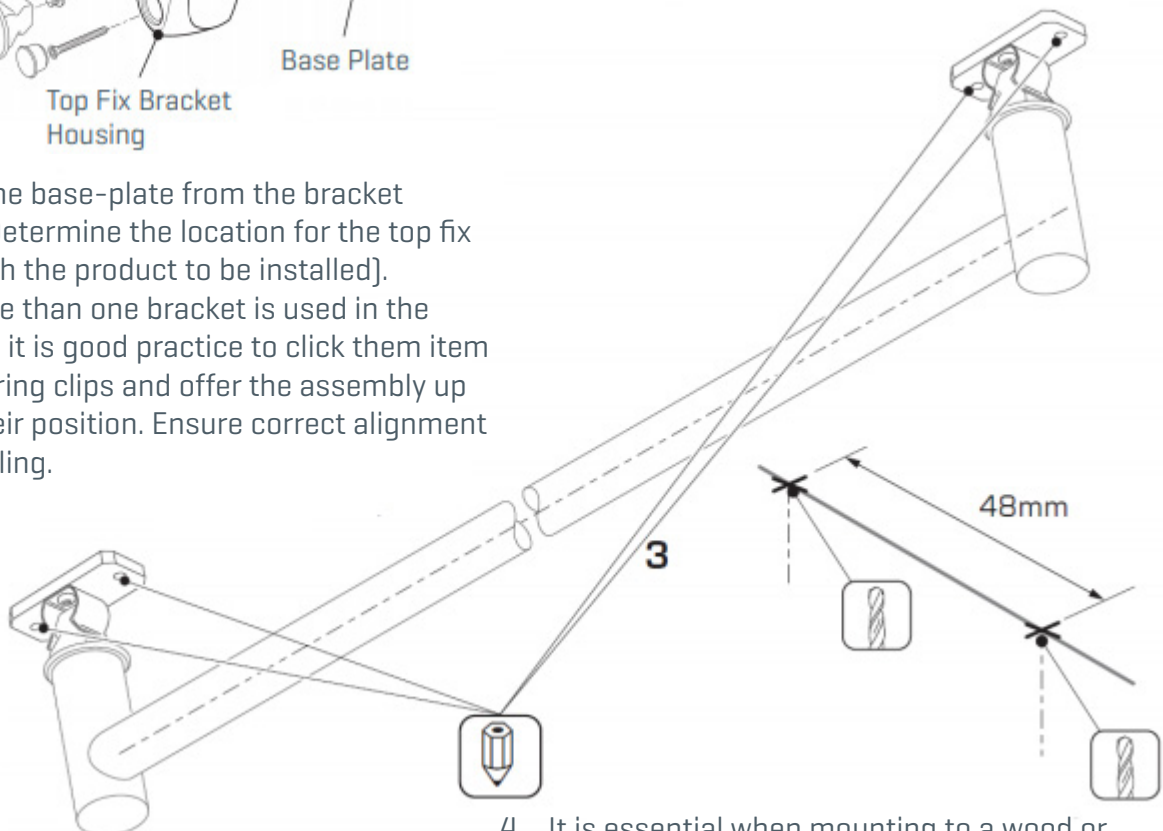

4. It is essential when mounting to a wood or laminate surface to drill a pilot hole using a suitable drill bit.

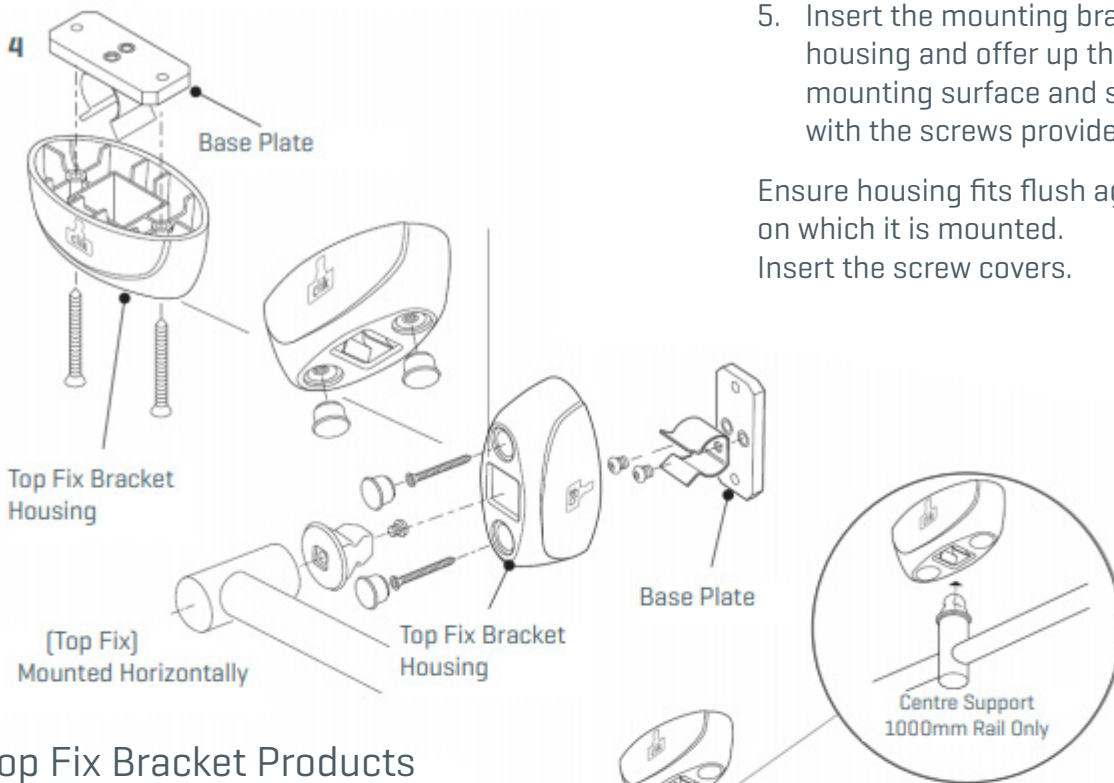

5. Insert the mounting bracket into the housing and offer up the assembly to the mounting surface and secure into position with the screws provided

Ensure housing fits flush against the surface on which it is mounted.
Insert the screw covers.

Top Fix Bracket Products Wardrobe Rail

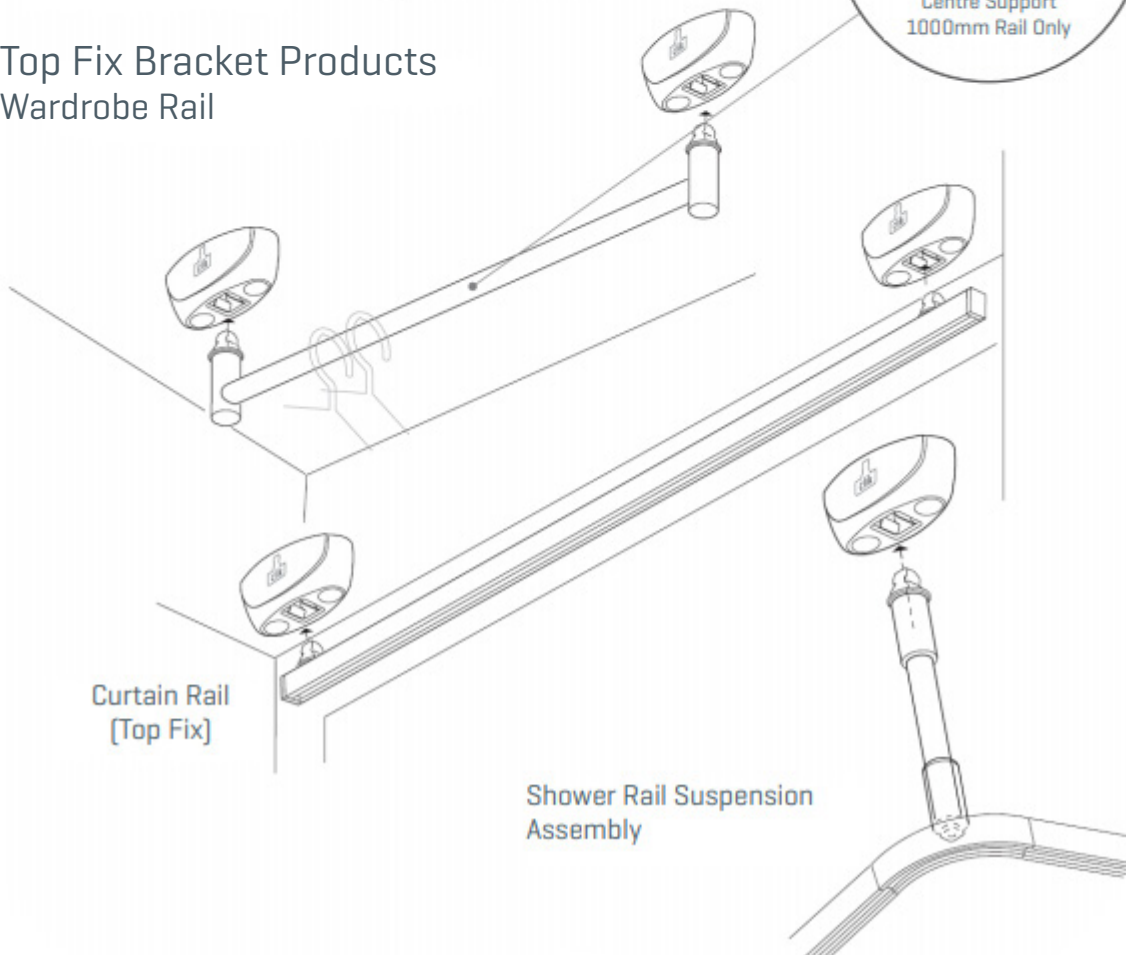



Top Fix Bracket Shower Rail Extension Assembly

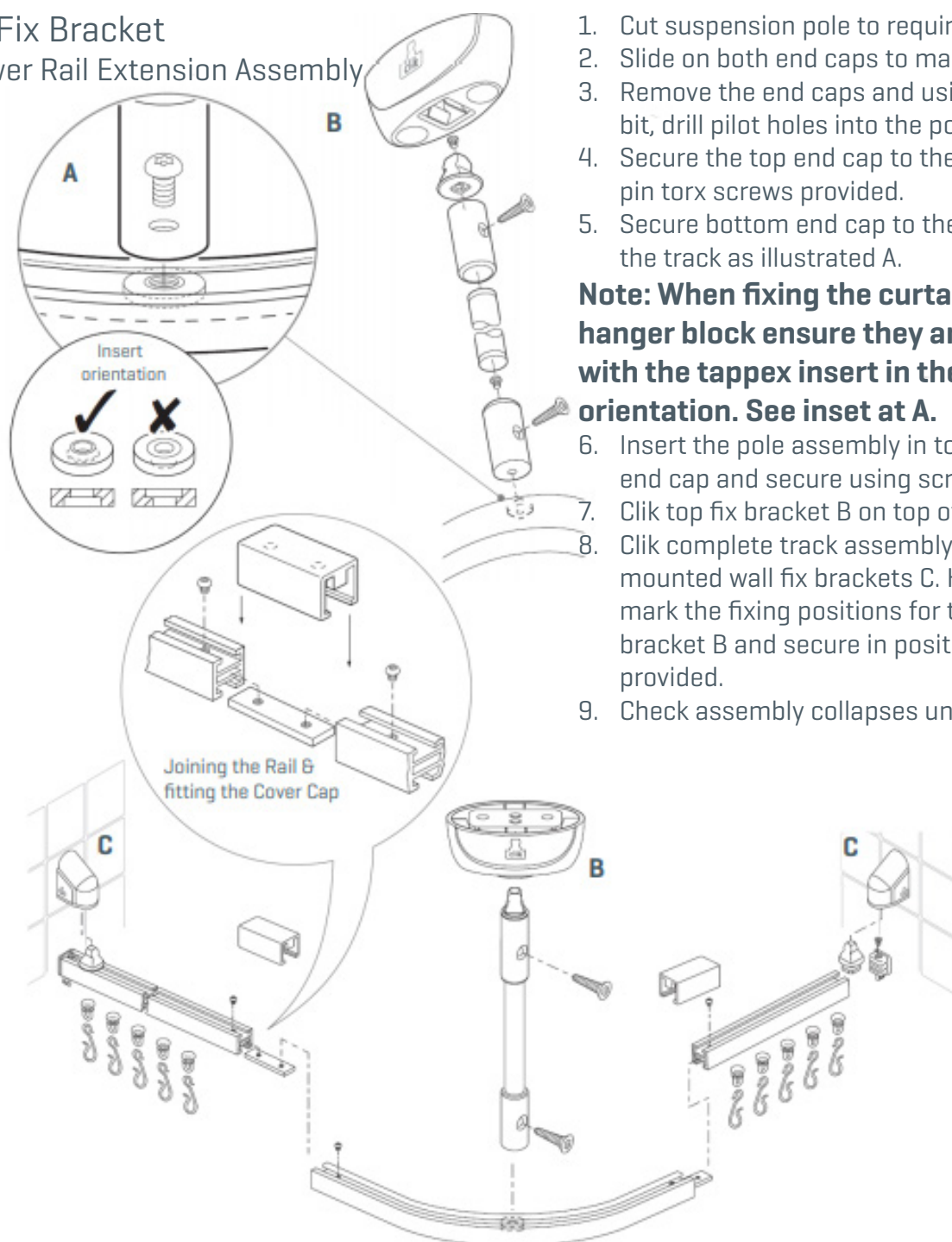

1. Cut suspension pole to required length.
 2. Slide on both end caps to mark fixing holes
 3. Remove the end caps and using a suitable bit, drill pilot holes into the pole.
 4. Secure the top end cap to the pole using the pin torx screws provided.
 5. Secure bottom end cap to the glide block in the track as illustrated A.
- Note: When fixing the curtain track hanger block ensure they are fitted with the tappex insert in the correct orientation. See inset at A.**
6. Insert the pole assembly in to the bottom end cap and secure using screws provided.
 7. Klik top fix bracket B on top of pole assembly.
 8. Klik complete track assembly into the two mounted wall fix brackets C. Hold up and mark the fixing positions for the top fix bracket B and secure in position with fixings provided.
 9. Check assembly collapses under load.

ABOUT HIPAC

We are an Australian healthcare company that guarantees to stand behind all our medical products, both manufactured and imported, because we're here for the life of our products and clients.

PO Box 797, 36 Long St. Goulburn NSW 2580, Australia
P. +61 2 4823 0000 E. info@hipac.com.au

SYDNEY | MELBOURNE | BRISBANE | ADELAIDE | PERTH

hipac.com.au

ABN 27 600 353 688