



## J-Trac Ceiling Mounted Curtain Rail

### Installation Instructions

The curtain rail is designed to be ligature resistant and reduce risk of the rail or other parts becoming a weapon. Moreover, the curtain carriers release from the rail when additional weight is applied.

- Mounting shall be done so that the curtain rail fits tight against the surface it is mounted against. Uneven surfaces should be avoided. After installation check that no objects, wire, or string can be inserted between the rail and the wall/ceiling.
- The rail shall always be installed with an end stop at each end of the rail.
- Make sure that the rail is mounted with the straight side of the profile facing the wall (or window), [same side as the screw holes].
  - See Figure 1 and 2.
- The rail shall be fitted with countersunk security screws. The holes are adapted for counter sunk screws with a diameter of 5 mm and 10 mm head. Use all holes. Make sure that the head does not protrude from the rail.
- Two rails shall not be mounted parallel to each other in any way. Profiles facing each other create a ligature risk.
  - See Figure 3.
- When the rail is cut to the desired length, the distance to the nearest countersunk hole from each end of the rail may vary. Cut the rail so that the distance between the nearest countersunk hole and the end stop does not exceed 185 mm. No part of a countersunk hole covered by the endstop shall be visible. - See Figure 4
- The rail's countersunk holes are pre-drilled with a CC of 200 mm.

**Recommended Runner Spacing:** 7-8 runners per metre generally, where runners exceed 12 per track application specific testing is recommended [contact Hipac for assistance]. Large, weighted runners may be used at one or both ends as required for added stability.

**Fabric Recommendation:** Lightweight <300gsm

#### Load Release Guidance:

##### Runners

- 1 small runner – median release weight – 1.4kg
- 1 large weighted runner – median release weight – 3.8kg

##### Window Track Installations

- 16 runners – median release weight – 4.5kg
- 10 runners + 2 weighted runners – median release weight – 8.2kg

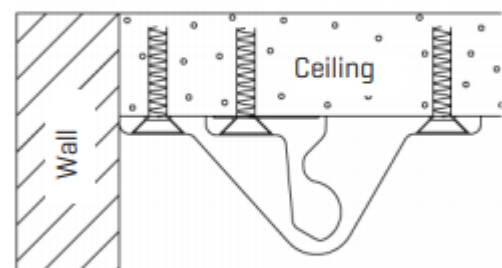
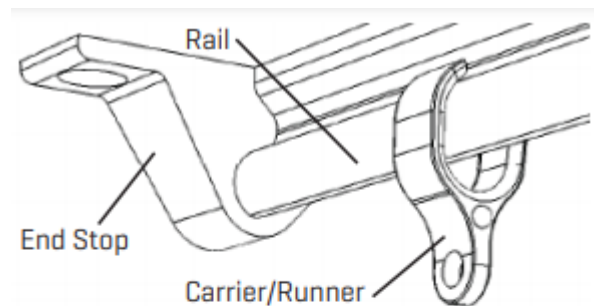

1. Correct placement facing the wall.

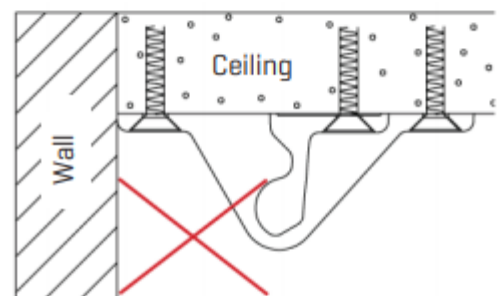

2. Incorrect placement facing the wall.

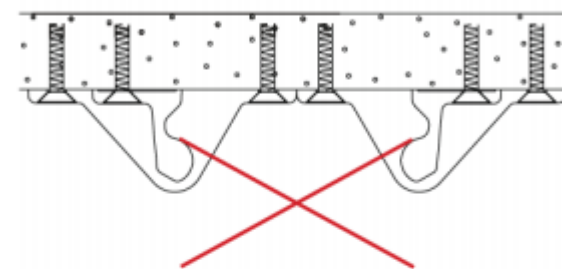

3. Incorrect placement of rails.

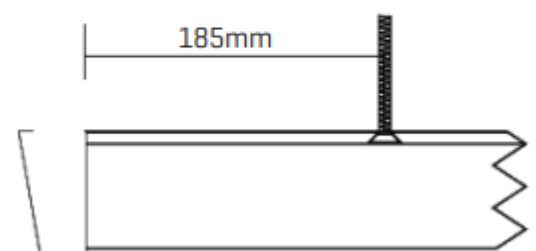

4. Distance between the nearest counter-sunk hole and end stop does not exceed 185 mm. No part of a countersunk hole covered by the endstop shall be visible.