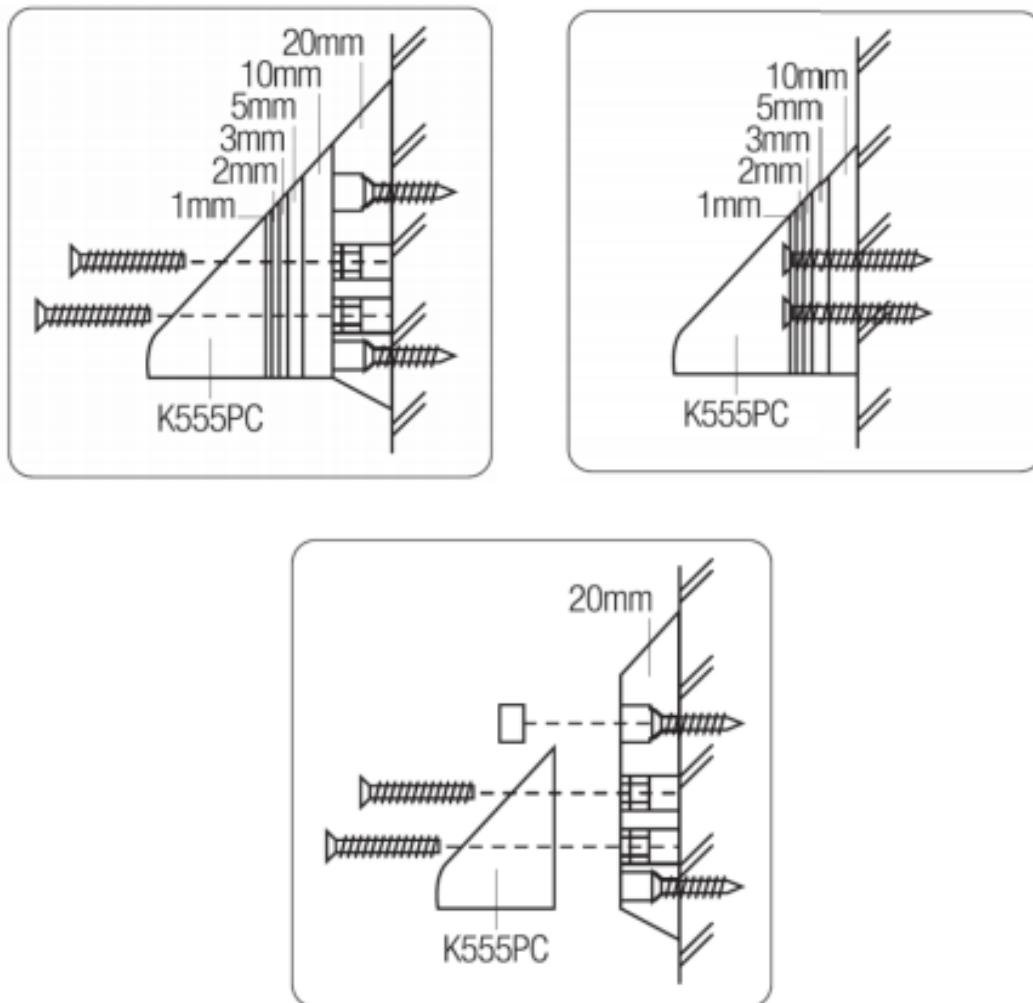



Fig 1.



### Fitting Instructions

1. Fix as shown in fig 1. It is important that the packers are securely fixed to the substrate using TWO fixing screws.
2. Once packers are fixed ensure there is no ligature point. NEVER fix a smaller packer behind a larger packer. See fig 2.
3. If a fixing hole is ever visible on the 20mm packer, the push-in screw cover must be fitted insuring that it is flush with the packer body. The push in screw cover is intended to be a tight fit to prevent unauthorized access to fixings.
4. Once packer is installed, proceed to fit the K555PC face fix bracket.



Fig 2.

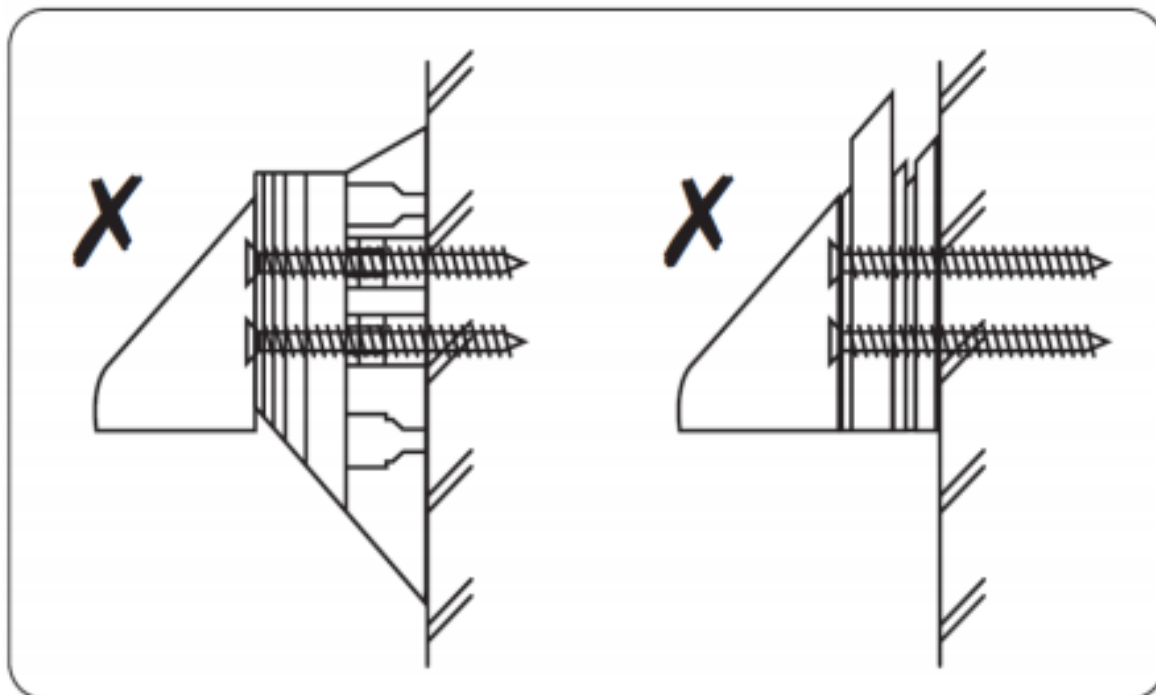

### All Brackets

Discs should be horizontal and centre of gravity of load should be directly beneath centre-line of discs. Test completed installation. The downward force needed to part the brackets should never be more than 400N [40kg static load] at any point

### Warning

The magnetic element of the Kestrel bracket is powerful. Handle with care. If allowed to attach to a flat steel surface it may be difficult to remove.

**DO NOT PLACE NEAR SENSITIVE ELECTRONIC EQUIPMENT**

### ABOUT HIPAC

We are an Australian healthcare company that guarantees to stand behind all our medical products, both manufactured and imported, because we're here for the life of our products and clients.

PO Box 797, 36 Long St. Goulburn NSW 2580, Australia  
P. +61 2 4823 0000 E. [info@hipac.com.au](mailto:info@hipac.com.au)

SYDNEY | MELBOURNE | BRISBANE | ADELAIDE | PERTH

[hipac.com.au](http://hipac.com.au)

ABN 27 600 353 688