

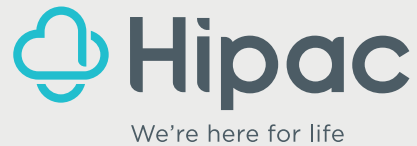





Mental Health Safety Furniture

 **Hipac**
We're here for life



Your specialists in:

-  Operating theatres and surgical spaces
 -  Mental health safety products and solutions
 -  Eco-friendly bio-medical waste solutions
-



www.hipac.com.au

Head Office & Manufacturing

Address:

36 Long Street, Goulburn New South Wales, 2580

Sydney Office & Warehouse

Address:

Unit 15, 16 Bernera Road, Prestons New South Wales, 2170

CONTENTS

Introduction	4
Key Features	6
Seating	8
Elan Chair	10
Taper Chair	11
Taper Chair with Armrests	12
Taper Lounging Chair	13
Slounger	14
Modular Ottomans	15
Modular Couch	16
Roto-moulded Stool	17
Tables	18
Roto-moulded Table	20
Reuleaux Coffee Table	21
Bedroom Furniture	22
Mental Health Beds	24
Bedside Locker - 2 and 3 Tier	25
Storage Shelf - 2 and 4 Tier	26
Wall Mounted Desk	27
Colours and Woodgrains	28

For almost forty years, Hipac has been dedicated to providing products and solutions for people in challenging environments.



Our Mental Health Safety Furniture is testament to this, offering an extensive range of furniture that combines safety, durability and visual appeal.

Carefully and meticulously designed for mental health units, correctional facilities and other challenging environments, our furniture range aims to protect people and create spaces that encourage normalisation and recovery.



Where Safety, Durability and Aesthetics Meet



Anti-stash Designs

Our furniture is designed with specialised environments in mind, prioritising the reduction of crevices and stashing spots to enhance safety and security.



Reduced Risk of Ligature and Harm

With smooth edges and curved lines, our furniture is designed to be ligature resistant, significantly reducing the chances of self-harm.



Ergonomic Designs

Combining comfort and durability with modern aesthetics our furniture pays careful consideration to safety by making it challenging to grip, lift and throw.



Weighted Stability

Additional weight reduces the likelihood of our products being lifted, thrown, or used as weapons. They can also be bolted to the floor for added stability.



Specially Formulated Material

The use of specially formulated compound material makes our products UV protective, flame retardant and resistant to impact, ensuring consistent and long lasting colours.



Exceptional Durability

Roto-moulded from a single piece of plastic eliminates moving parts that can break. This combined with the polymer material ensures long lasting durable products.



Water Resistant

Featuring anti-rust and easy to clean surfaces makes our products perfect for infection control and ideal for indoor and outdoor use.



Beauty and Aesthetics

Our products are built for durability, yet transform spaces with modern designs and vibrant, uplifting colours.

Seating

Our seating has been moulded with sleek silhouettes and curved lines to minimise ligature risk and prevent self harm and injury. This ensures a more robust and harder to damage product. Enhancing patient safety is at the forefront of our designs.





SKU#147216

Elan Chair

A seamless one piece roto-moulded construction with armrests. This ergonomic design is perfect for lounging and is available in a range of stylish colours. It can be filled with sand to increase the total weight.

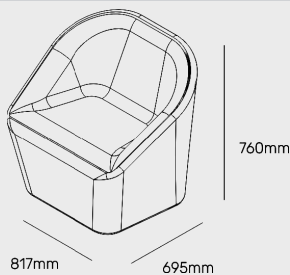
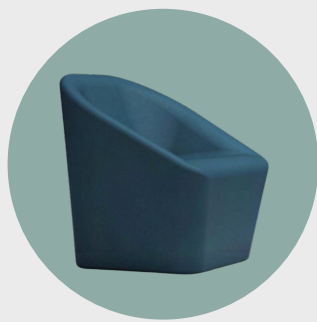
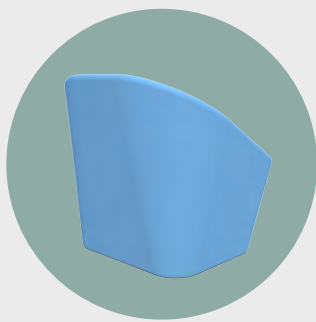
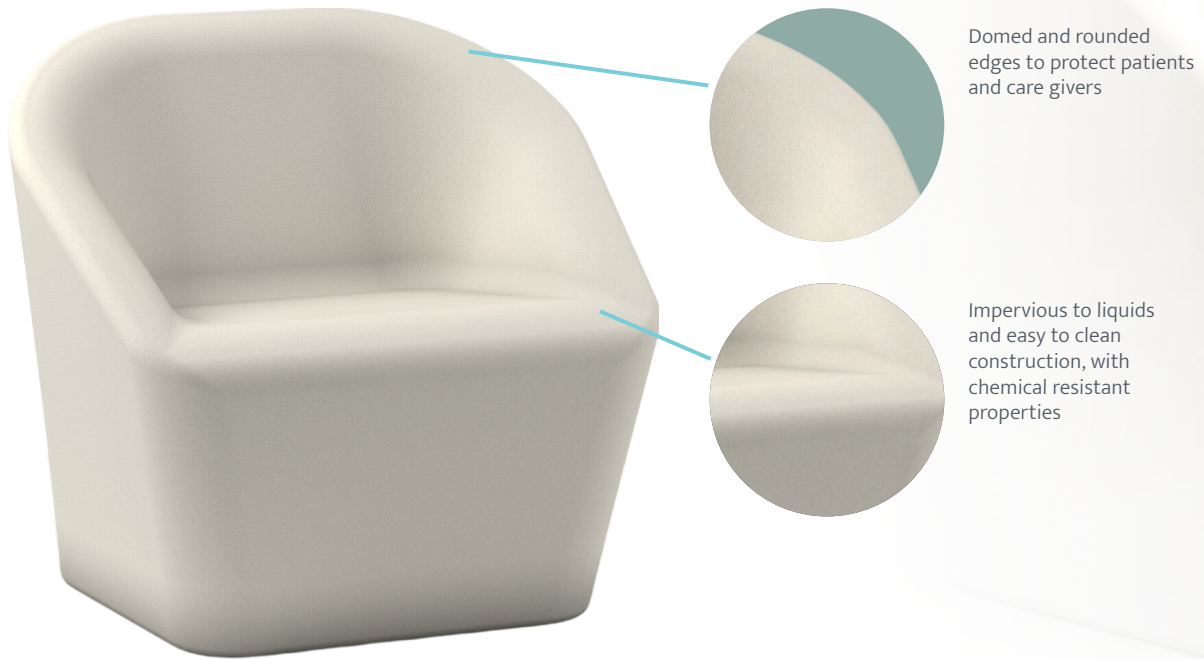

Weight	7kgs (without sand)
Material	LLDPE Fire retardant and UV stabilised
Note	can be filled with sand

SKU#147213

Taper Chair

A seamless one piece roto-moulded construction suitable for any room in your facility. It can be filled with sand to increase the total weight.

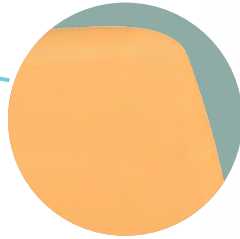

Domed and rounded edges to protect patients and care givers

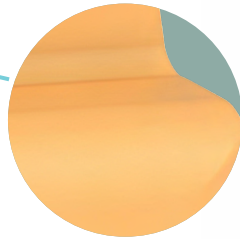

Impervious to liquids and easy to clean construction, with chemical resistant properties

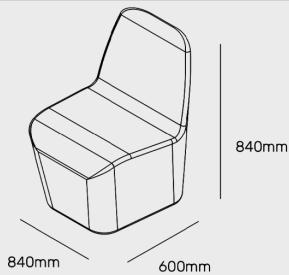
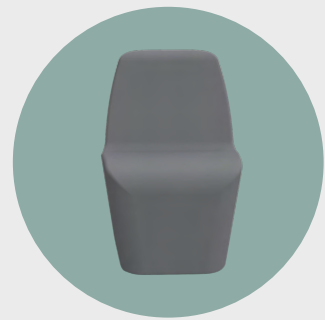
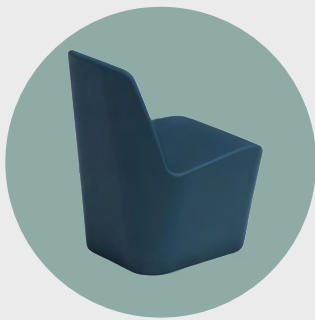

Weight

7kgs (without sand)

Material

LLDPE
Fire retardant and UV stabilised

Note

can be filled with sand

SKU#147214

Taper Chair with Armrests

A seamless one piece roto-moulded construction with armrests. Perfect for people requiring support to stand or sit. It can be filled with sand to increase the total weight.

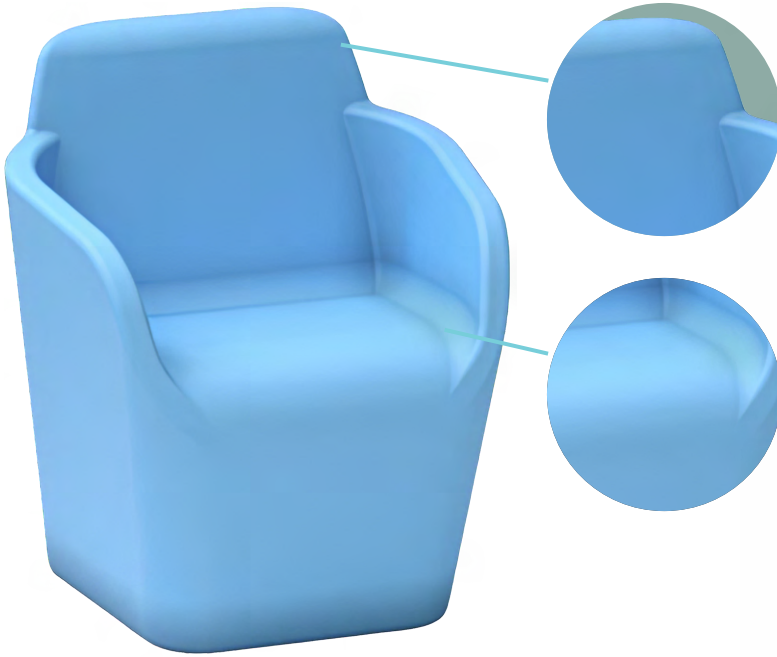

Domed and rounded edges to protect patients and care givers

Impervious to liquids and easy to clean construction, with chemical resistant properties

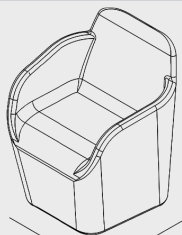

840mm

721mm

667mm

Weight

7kgs (without sand)

Material

LLDPE
Fire retardant and UV stabilised

Note

can be filled with sand

SKU#147215

Taper Lounging Chair

Moulded with a sleek silhouette and gentle curves and slightly wider than the Taper chair, offering more room to move and relax. It can be filled with sand to increase the total weight.

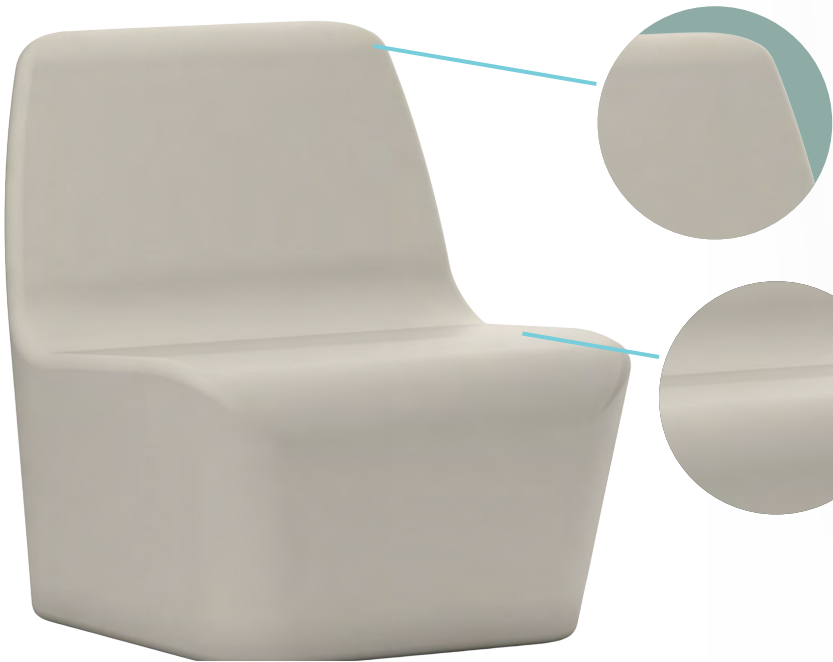

Domed and rounded edges to protect patients and care givers

Impervious to liquids and easy to clean construction, with chemical resistant properties

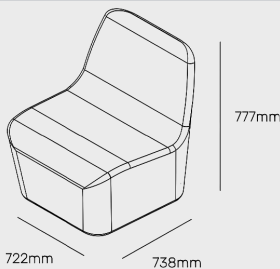

Weight	7kgs (without sand)
Material	LLDPE Fire retardant and UV stabilised
Note	can be filled with sand

SKU#147230

Slounger

Modern and space conscious, the Slounger offers a stylish and playful furniture option for a range of facility settings. Made with high density flame retardant foam core.

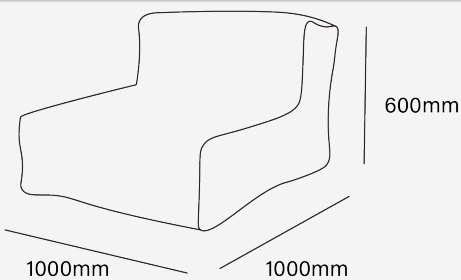
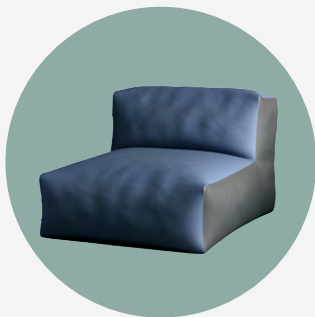
**Weight**

25kgs

Material30 Density flame retardant foam core
Heavy duty PVC

Modular, SKU#147225

Round, SKU#147226

Oblong, SKU#147228

Modular Ottomans

A set of seating items that can be combined to create a different arrangement. Made with an upholstered flame retardant core and roto-moulded table base that can be filled with sand.

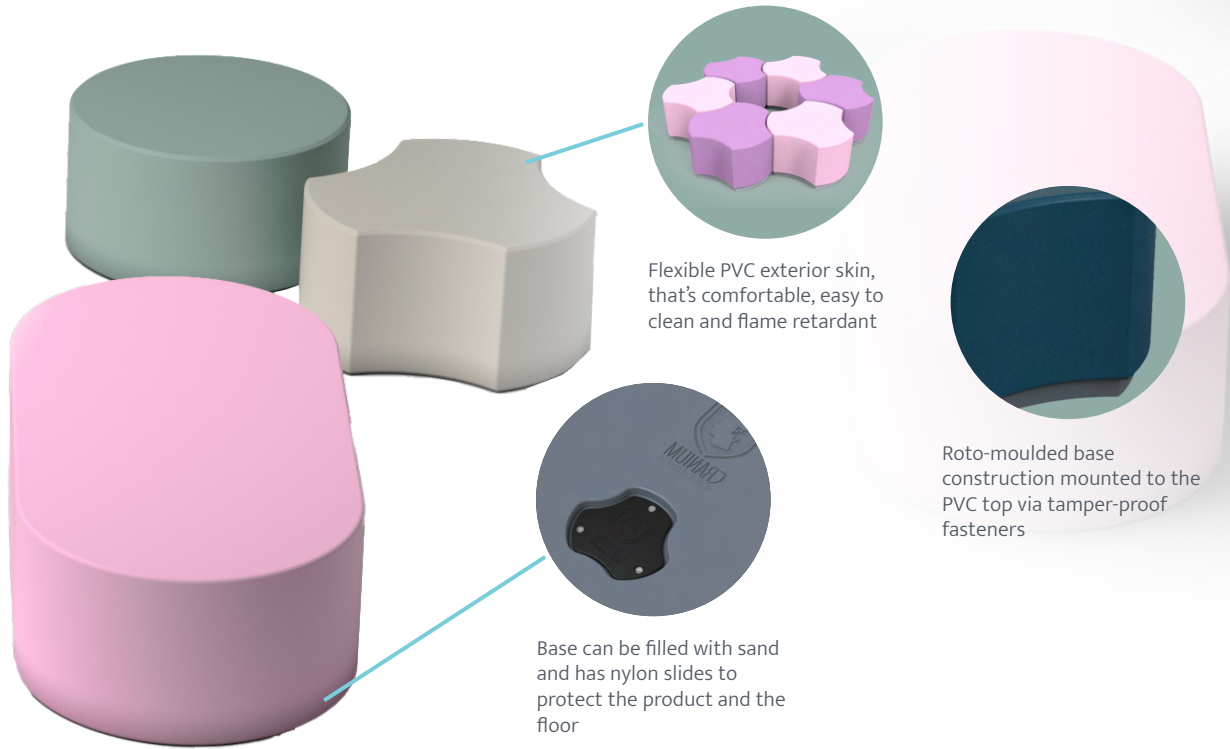

Weight	6kgs (without sand)	Material	LLDPE Fire retardant and UV stabilised	Note	can be filled with sand

SKU#147218

Modular Couch

A set of seating items that can be combined to make a different arrangement. Made from a strong wooden centre construction that is assembled together with no visible fasteners. A soft interior core is made with multiple layers of flame retardant foam that is then upholstered with a flame retardant material. Available in a variety of colors.

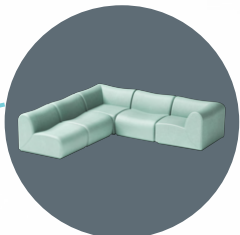
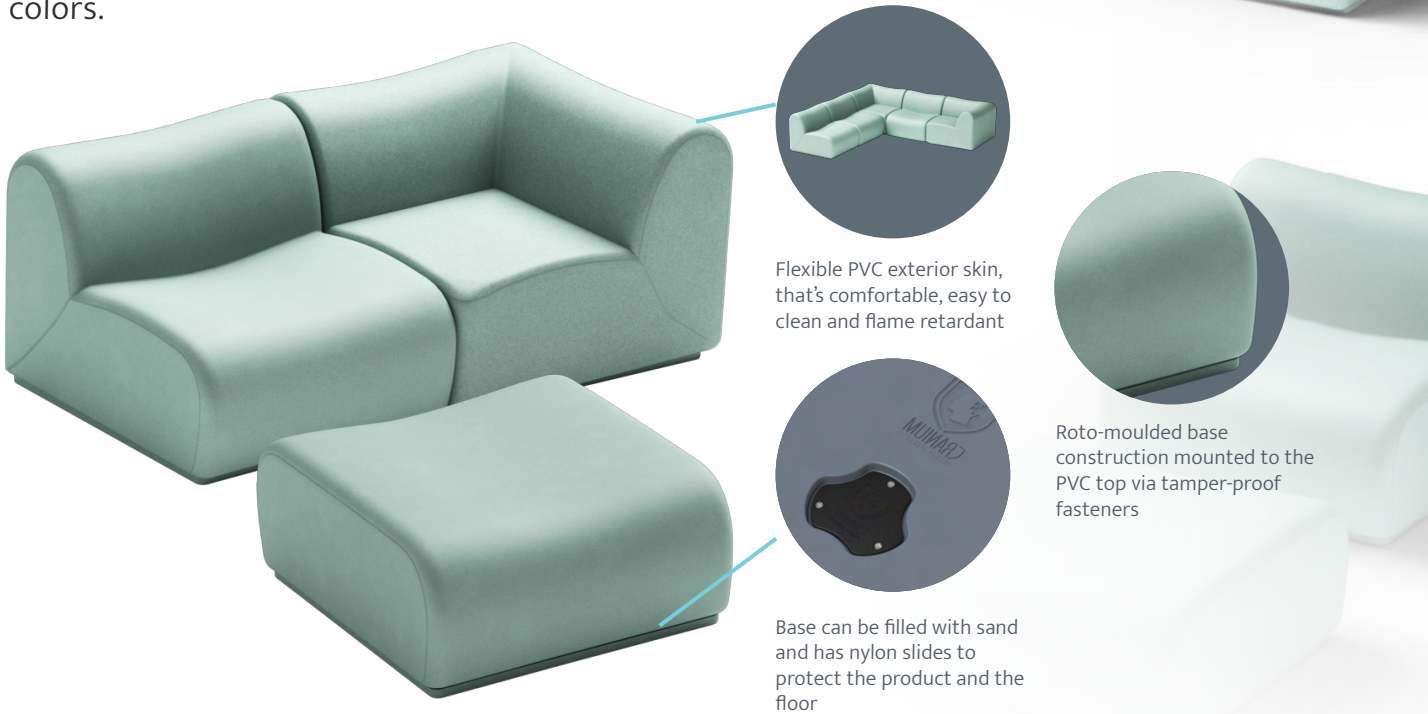

Flexible PVC exterior skin, that's comfortable, easy to clean and flame retardant

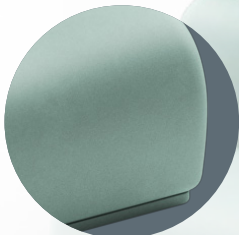

Roto-moulded base construction mounted to the PVC top via tamper-proof fasteners



Base can be filled with sand and has nylon slides to protect the product and the floor

<p>Weight</p>	<p>6kgs (without sand)</p>	<p>Material</p>	<p>LLDPE Fire retardant and UV stabilised</p>	<p>Note</p>	<p>can be filled with sand</p>

SKU#147217

Roto-moulded Stool

A single seat offering a relaxed seating option to recreational areas or patient bedrooms. Can be anchored to the floor for added security.

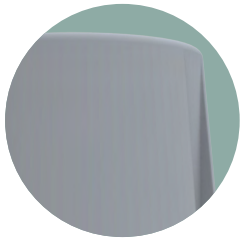

Durable, ergonomic and comfortable design. Domed and rounded edges to protect patients and care givers



Can be anchored to the floor via 3 high tensile strength stainless steel tamper-proof fasteners

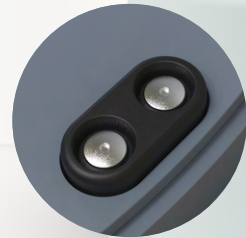

Nylon slides can be applied to prevent scuffing on floors



Can be filled with sand via plugged hole for additional weight preventing stool from being moved

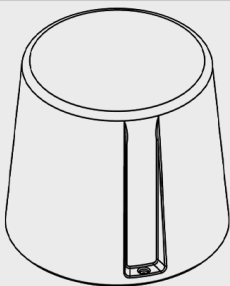

Ø472mm

418mm

Weight

5kgs (without sand)

Material

Polyurethane
Fire retardant and UV stabilised

Note

can be filled with sand
can be anchored to the floor

Tables

Our smooth edged tables are designed to enhance both safety and comfort in mental health environments. By eliminating sharp corners, they reduce the risk of injury and self-harm, while the gentle curves create a calming, welcoming atmosphere.





SKU#147238

Roto-moulded Table

A recreational table with a compact laminate top and roto-moulded base that can be filled with sand or anchored. The anti-scratch table surface is easy to clean and is available in a variety of colours and wood grain finishes

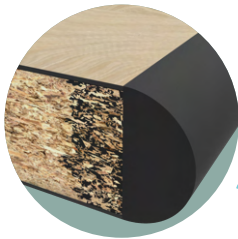

Anti-pick and tamper-proof edging that is extremely tough, durable and is permanently fixed



Anti-scratch surface that is easy to clean and comes in a variety of colour and wood grain finishes. Ensuring a warm and homely environment



Roto-moulded base which can be filled with sand or bolted to the floor

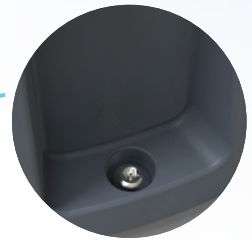

Tamper-proof screws secured into robust inserts fasten the legs to the table top

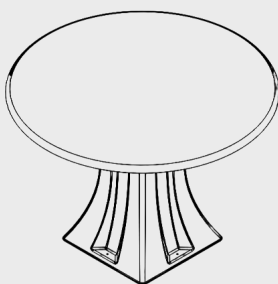

832mm

Ø900mm

Material

Polyurethane base
 Fire retardant and UV stabilised
 Compact laminate
 Rubber bumper surround

Note

can be filled with sand
 can be anchored to the floor

SKU#147234

Reuleaux Coffee Table

A coffee table with an extremely strong roto-moulded base and optional HPL table top.

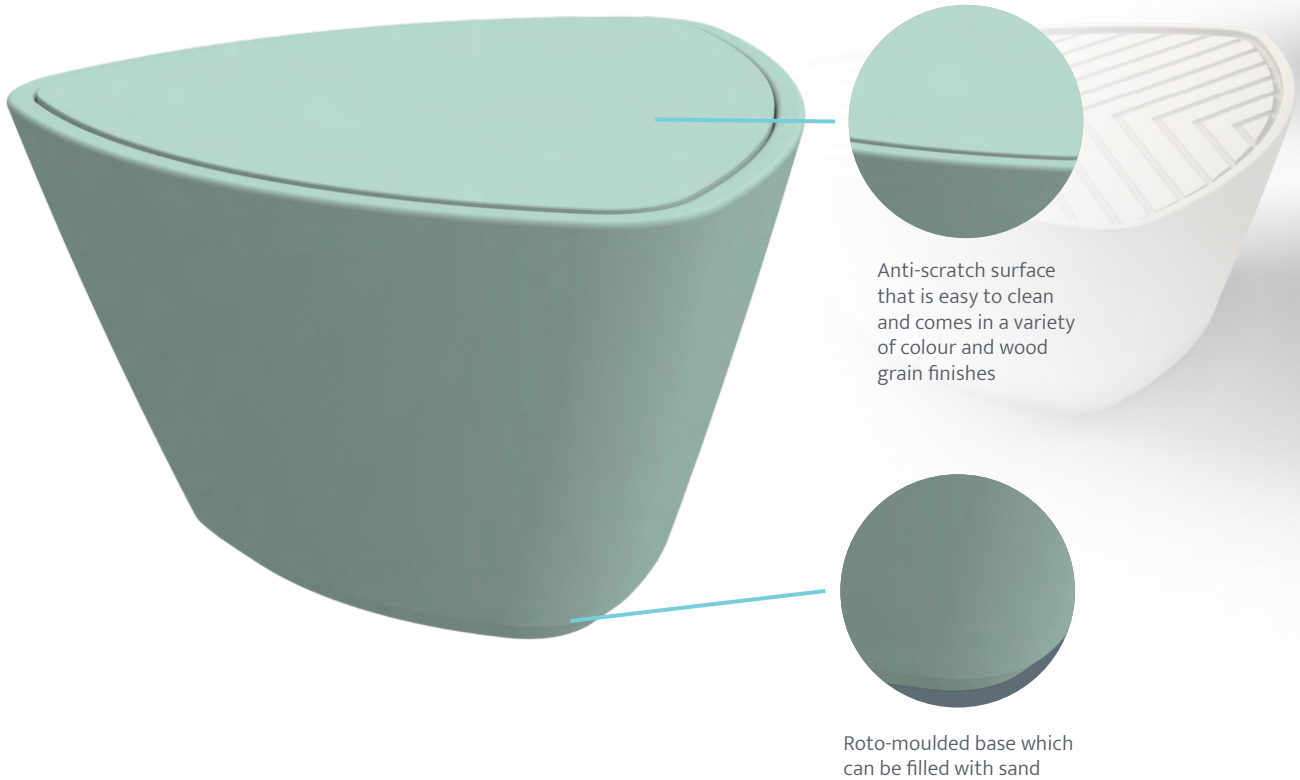

<p>993mm 997mm 410mm</p>	<p>Material</p> <p>Polyurethane Fire retardant and UV Stabilized HPL Laminate table top</p>	<p>Note</p> <p>can be filled with sand</p>

Bedroom Furniture

Our range of bedroom furniture has been expertly curated to foster deep rest, restoration and rehabilitation, all whilst ensuring safety and security.

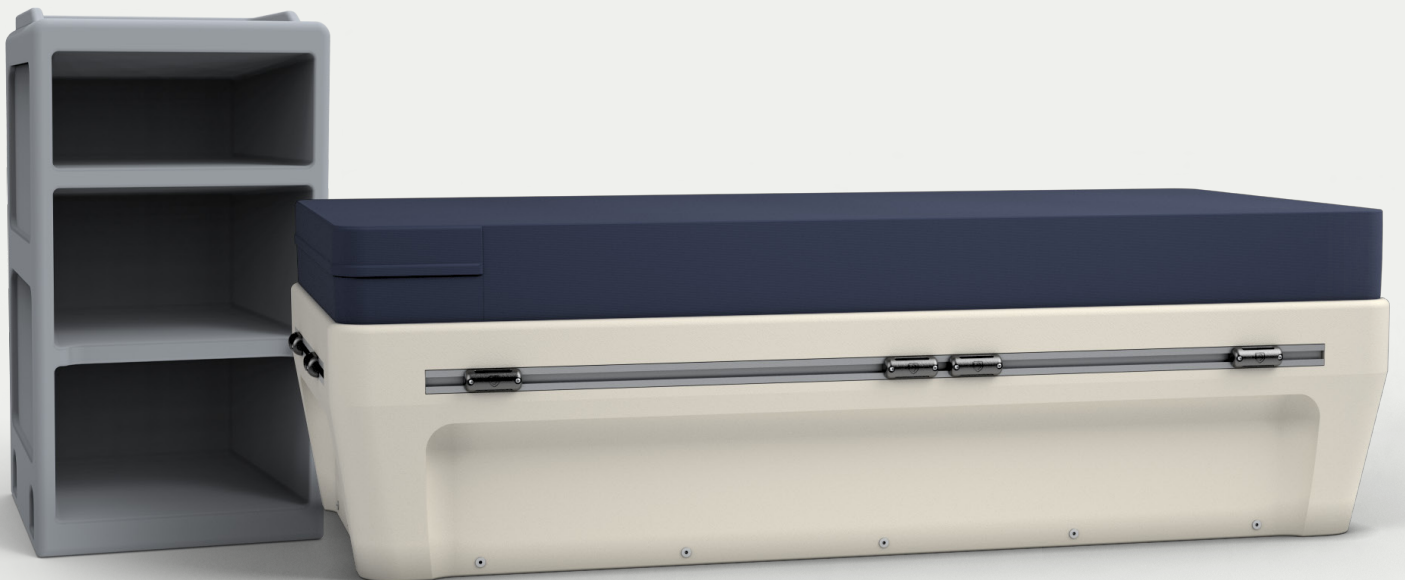



SKU#147200

Mental Health Beds

The bed can incorporate a completely adjustable restraining system. This system has sliding rails with anchors, which create fixture points for multiple restraint combinations. Anchor points are fixed by way of specialised tool.



Domed and rounded edges to protect patients and care givers

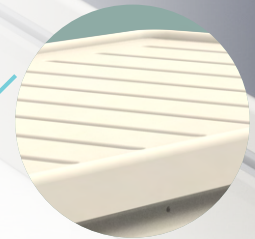

Impervious to liquids and easy to clean construction with chemical resistant properties



Can be anchored to the floor via high tensile strength stainless steel proof fasteners

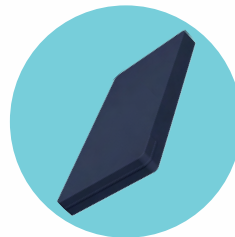

Available with optional mattress



Fitted with the restraining system which consists of a unique recessed aluminium extrusion and a nylon adjustable slide

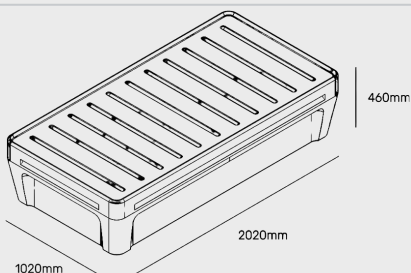
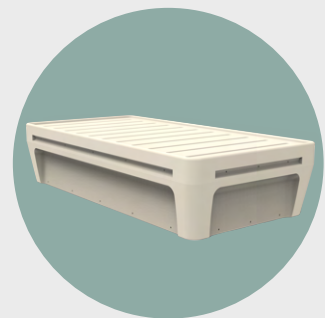

Weight	35kgs
Material	Polyurethane Fire retardant and UV stabilised
Note	can be anchored to the floor

2 Tier, SKU#147211

3 Tier, SKU#147212

Bedside Locker - 2 and 3 Tier

Seamless one piece roto-moulded bedside locker. Ideal for personal belongings or as a night stand.



Soft corners and edges to ensure safety of patients and care givers. Added ribbing to ensure structural integrity and increase overall strength

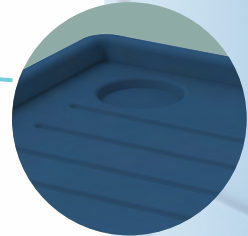

One piece seamless flame retardant design for ease of cleaning and prevention of any fluid ingress

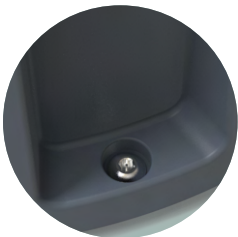

Can be anchored to the floor via 4 high tensile strength stainless steel tamper-proof fasteners



Shelf design ideal for patient belongings. Designed to withstand even the toughest environments

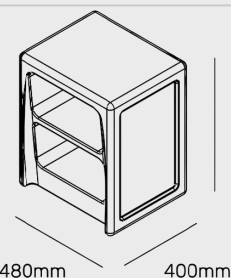

585mm

480mm

400mm

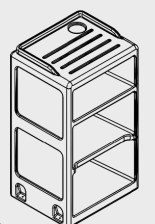

875mm

480mm

400mm

Weight

10kgs (without sand)

Material

Polyurethane
Fire retardant and UV stabilised

Note

can be anchored to the floor

2 Tier, SKU#147241

4 Tier, SKU#147240

Storage Shelf - 2 and 4 Tier

Wall mounted open storage for displaying or storing items.

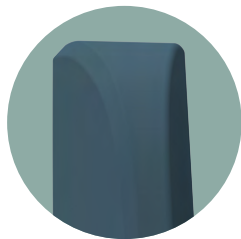

Durable, ergonomic and comfortable design. Domed and rounded edges to protect patients and care givers



Anchored to the wall via 6 high tensile strength stainless steel tamper-proof fasteners

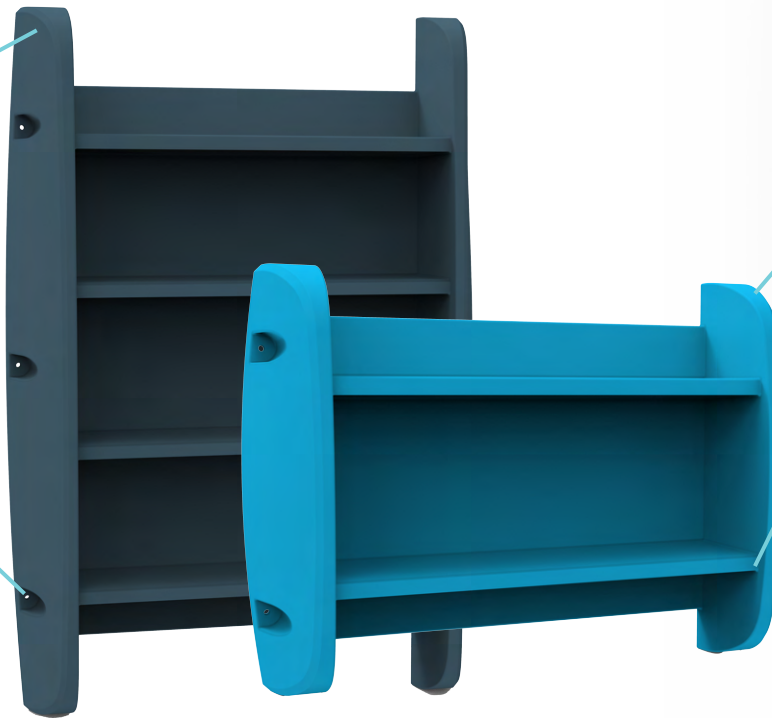

Ligature resistant



One piece seamless flame retardant design for ease of cleaning and prevention of any fluid ingress

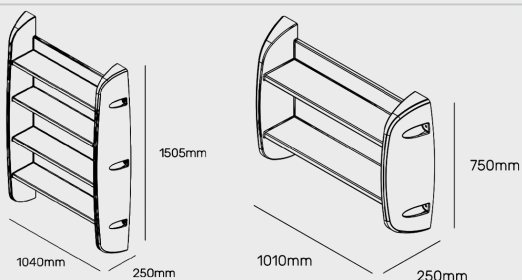
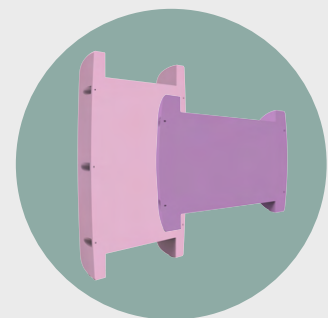

Weight

12kgs - 4 Tier, 5kgs - 2 Tier (without sand)

Material

Polyurethane
Fire retardant and UV stabilised

SKU#147242

Wall Mounted Desk

Read, write or do other work with this wall anchored workstation.

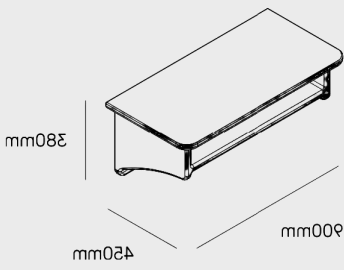
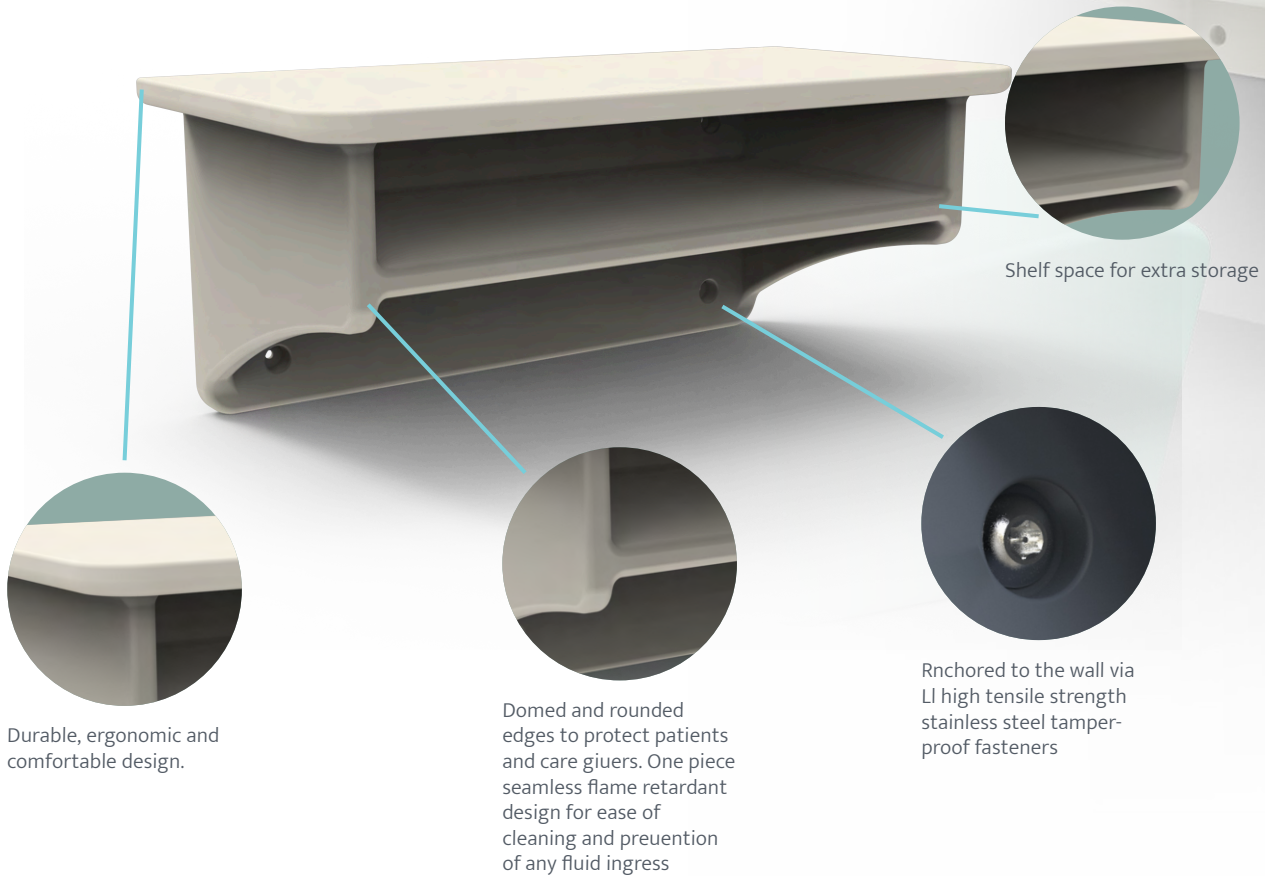

Weight	10kgs (without sand)
Material	Polyurethane Fire retardant and UV stabilised

Colours and Woodgrains

Our mental health safety furniture is available in a range of modern, uplifting colors, designed to create a serene and tranquil atmosphere to help reduce stress and anxiety.



The use of specific wood grains also plays a vital role. Natural materials like wood are often associated with warmth, comfort, and a connection to nature, all of which are essential in creating a nurturing environment.

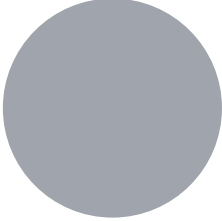
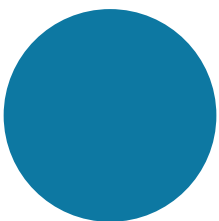
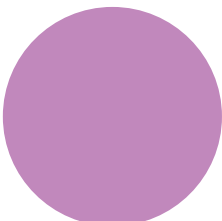

Colours

			
Gull Wing	Birch Grey	Granite	Walk Away
			
Torres Blue	Basalt Gray	Blue Crane	Peach Melba
			
Dearley	Hear Me Roar	Endless Summer	Night Out

Woodgrains

		
Verona Walnut	Country Oak	Classic Maple







Creating a healthier tomorrow

Operating at the forefront of healthcare, we strive to redefine what's possible. We provide superior products, design expertise and total solutions to help create environments where nothing stands in the way of patient care.



Your specialists in:



Operating theatres
and surgical spaces



Mental health safety
products and solutions



Eco-friendly bio-medical
waste solutions

Contact information



1800 75 93 93



info@hipac.com.au



www.hipac.com.au



We're here for life